

NOVIDADES

candeeiros . lâmpadas . componentes

Projector LED Solar – Série DALTON

LUMIT®



Projector LED Solar com SENSOR MOVIMENTO



sensor PIR

Ref. A19361509S

LED 15W | 1600lm | 6000K

Medida. ± 23,1 x 5,8 x 49,2cm (l x a x p)

Bateria Lítio (substituível). 2x 7.4V - 5400mAh

15W / 1600lm / 6000K

painel solar 9.5Wp • Silício monocristalino



super luz



ultra-fino



painel solar



ajustável

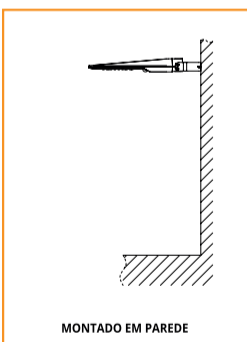

MONTADO EM PAREDE

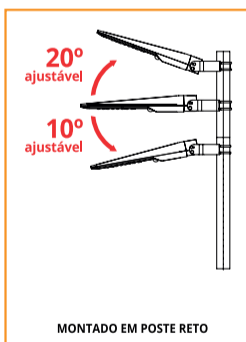

MONTADO EM POSTE RETO

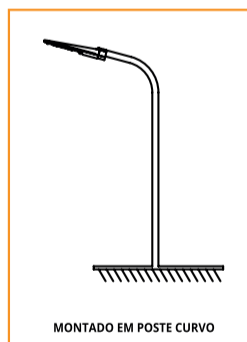

MONTADO EM POSTE CURVO

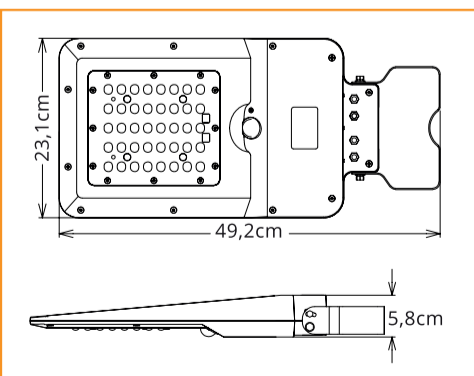

VEJA TODOS OS PRODUTOS EM WWW.INTERLUSA.COM

SIGA-NOS NO FACEBOOK



VENDA A PROFISSIONAIS E REVENDEDORES | PARA MAIS INFORMAÇÕES CONTACTE-NOS OU CONSULTE O NOSSO WEBSITE

Interlusa® — Manfred H. Müller & Ca. Lda.

Estrada Interior da Circunvalação 12477 | 4100-178 Porto, Portugal

+351 22 610 23 93

+351 22 610 34 23

WWW.INTERLUSA.COM

rlight@interlusa.com